



Town of Drumheller New Automated Residential Waste Collection – Frequently Asked Questions

1. What is automated collection?

Automated collection is a system where a specially designed truck picks up automated collection carts, empties them, and then returns the carts to their original positions.

2. How will it work?

Each residence will be supplied with a specially designed wheeled cart. On collection day, residents wheel their cart to their set location in the alley or street. The cart would be emptied using trucks equipped with a mechanical arm. The cart should then be stored on the resident's property until the next collection day. All garbage must be bagged to ensure the cart empties completely and to ensure loose litter is contained.

3. When will I get my cart?

Cart distribution will begin in June and should be completed by the end of June. The Town, at no charge, will supply and deliver the automated waste collection carts to residents who are currently on manual waste collection.

4. Why change from the existing manual system?

Cleaner, safer, and economically viable.

For Residents

- No more lifting heavy bags – simply roll your cart out for collection
- The cart acts as an enclosure – keeps animals out of bags – less litter
- No need to purchase waste cans – the Town supplies your cart

For the Town of Drumheller and Contractors

- Reduced worker compensation (WCB) costs
- Cleaner community – less litter
- Improves collection efficiency

For Waste Collection

- Reduced injury from fatigue and lifting – collectors now lift up to 20,000 pounds per day
- Reduced handling of dangerous and infectious waste – safer work environment

5. Do I need to buy the cart?

No, the Town will supply the cart. The cost of the cart is included in the annual fee for collection service. The carts will remain the property of the Town of Drumheller.

6. When will my garbage be picked up?

Your collection day for the automated carts will stay the same as for the manual collection system.

7. What happens to the cart when I move?

Automated carts remain the property of the Town of Drumheller. If you move, leave the cart at the original property, stored safely in a secure place. The Town will assign a cart to each property with the serial number clearly marked on the cart. A serial number on each cart links the cart to the assigned property.

8. What colour is the container?

The carts are charcoal grey.

9. Can I use regular garbage cans if my cart is full?

No, regular garbage cans are not designed to be emptied by the automated waste collection truck. There is no option for additional garbage. Experience in other municipalities has shown the standard 5 bag capacity to be the optimum size for most residents, allowing enough capacity for seasonal increases in waste. Residents are encouraged to consider donation, recycling or composting for additional waste diversion.

10. What can I do with my old garbage cans?

Residents are encouraged to reuse old garbage cans for other applications around the home or yard.

11. Where do I place my cart for pick-up?

Placement of the cart for collection is important. In most cases if you are currently having your garbage collected in the alley we will be emptying your cart in the alley. If your garbage is being collected in the front we will empty your cart in the front. Detailed information on how to use and set out the container will be provided with the container upon delivery. If you have any other questions you may call us at 403-823-1358 or visit www.dinosaurvalley.com

The automated collection arm requires room to grab the cart. Please ensure that your cart is clear 1 meter or 3 feet from all obstacles such as parked cars, poles, hedges, etc. at front and sides of cart. Place wheels at least ½ metre from the back of a hedge or fence. Park the cart on level ground. Point the arrows on the lid toward the center of the road or alley.

12. Why wasn't my garbage picked up?

The Town has a very dependable, automated waste collection system and your cart should be emptied each week. However, there are some reasons why your garbage may not be picked up:

- Not enough space on the sides or back of the cart
- Lid not closed
- Cart parked too close to trees or other obstacles
- Cart (arrows) facing the wrong direction
- Garbage on top of the cart
- Cart not out by 7 a.m.
- Cart overfilled
- Garbage not bagged

13. How big are the carts?

The carts are 360 litre (95 gallon) are 46" tall by 34" width. They all have large wheels so they can be moved easily.

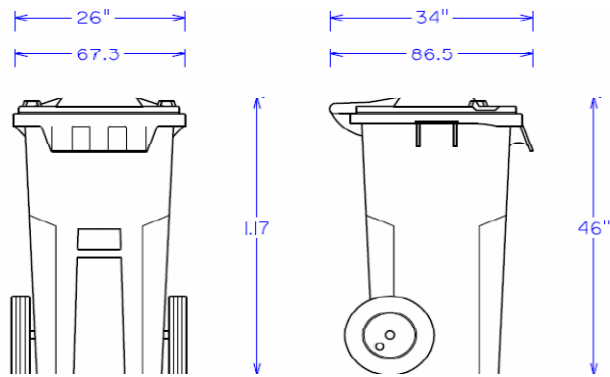

14. Who is responsible for my cart?

Residents are responsible for keeping their cart clean and secure. Residents must return their cart to their property after collection. If damage or vandalism of the cart results from negligence, residents will be responsible for the replacement cost of the cart (\$100).

15. What if my cart is lost, stolen, or damaged?

Automated carts remain the property of the Town of Drumheller. Residents are responsible for routine maintenance such as keeping the carts clean and storing the carts in a safe place after they are empty. Contact Infrastructure Services at 403-823-1358 if your cart is lost, stolen, or damaged. If damage or loss of the cart results from neglect, residents will be responsible for the replacement cost of the cart (\$100).

16. Where do I store my cart?

Most residents choose to store carts in a convenient location such as their carport, garage or at the side of their house or just inside their fence. Carts should be stored on your property between collections for security reasons. Carts left in the alley are exposed to theft, vandalism, and fires.

17. How full can I fill the cart?

Carts should not be filled to a height greater than 5 cm from the top. You **MUST** be able to close the lid completely after the garbage is placed inside.

18. What types of waste are not collected at my residence?

Materials not taken during regular collection are:

- Large, bulky material such as mattresses, furniture & appliances (fridges, stoves, freezers, dishwashers, hot water tanks, etc.)
- Construction or demolition materials: concrete, gravel wood, etc.
- Large organics: shrubs, trees & branches, stumps, sod & dirt.
- Hazardous Waste: auto parts, paint, computer hardware, chemicals, oven cleaners, motor oil, pesticides, toilet cleaners, batteries, propane tanks, light bulbs, solvents, computer equipment
- Electronic equipment
- Automobile tires